

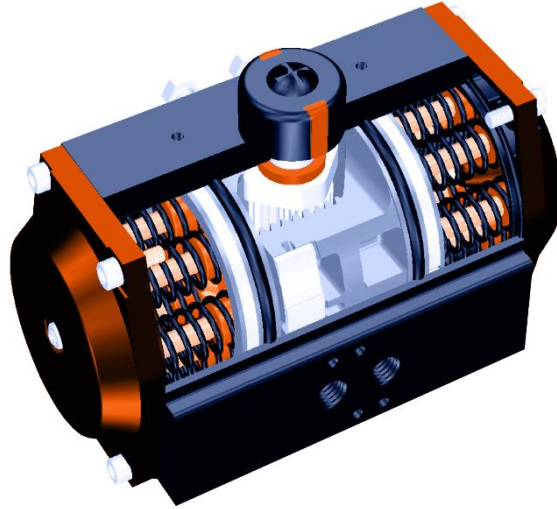

Catalogue of fluid valve for pneumatic actuators





PA 10 series aluminum rack & pinion pneumatic actuator



CONTENTS

Design and structure	P3
Operating principle.....	P4
Assemble parts and material.....	P5
Dimension drawings and table.....	P6-P7
Out torque table of double acting.....	P8
Out torque table of spring return.....	P8-P9-P10
Air Consumption.....	P10
Weight.....	P10
Operation conditions.....	P11
Manual of sizing and operation.....	P11
Sizing.....	P11
Springs mounting.....	P12
Assembly with valve.....	P12
Maintenance.....	P13

Design

Our newly-designed SMART Series Pneumatic Actuator is aluminum rack & pinion actuators in double acting and spring return based on our innovative and patented technology. This kind of actuator features a top mount multifunction indicator and open-close stop adjustment as a standard. In addition, state-of-the-art engineering has allowed us to reduce the size of the actuator without losing any torque. The features and characteristics of the actuator have kept pace with 4th generation pneumatic actuator in the world.

Structure

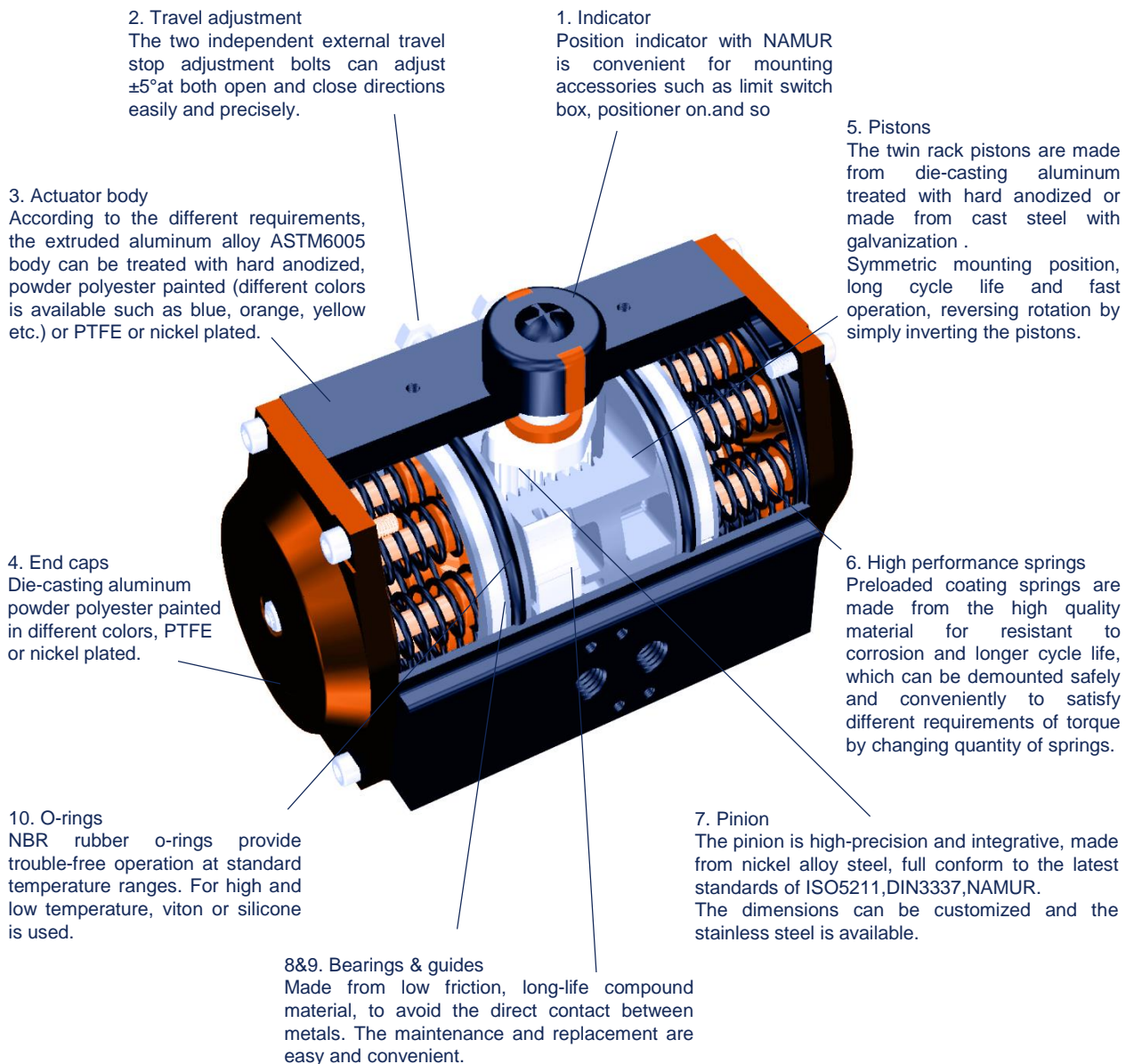

Operating Principle

Double acting

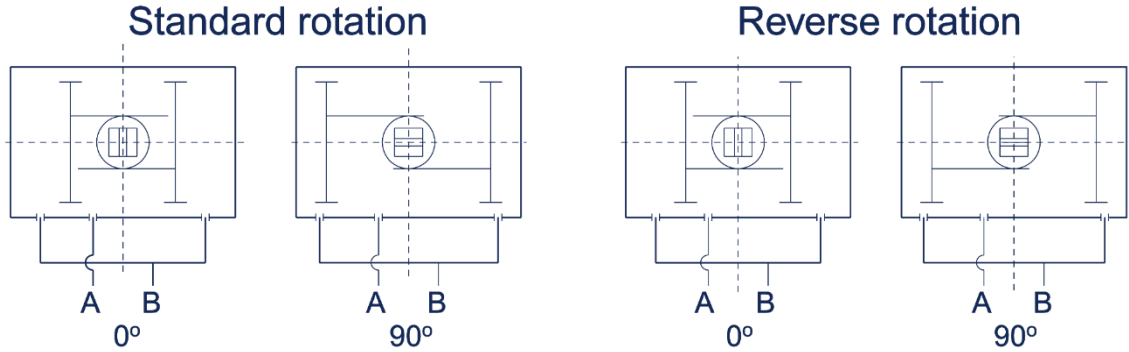

Standard Rotation:

Air to port A forces the pistons outwards, causing the pinion to turn counterclockwise while the air is being exhausted from port B. Air to port B forces the pistons inwards, causing the pinion to turn clockwise while the air is being exhausted from port A.

Reverse Rotation:

Air to port A forces the pistons outwards, causing the pinion to turn clockwise while the air is being exhausted from port B. Air to port B forces the pistons inwards, causing the pinion to turn counterclockwise while the air is being exhausted from port A.

Spring return

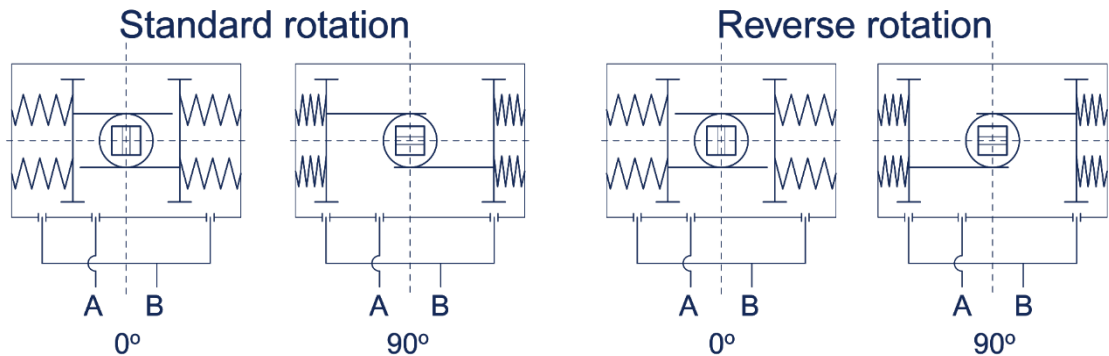

Standard Rotation:

Air to port A forces the pistons outwards, causing the springs to compress, the pinion turns counterclockwise while air is being exhausted from port B. Loss of air pressure on port A, the stored energy in the springs forces the pistons inwards. The pinion turns clockwise while air is being exhausted from port A.

Reverse Rotation:

Air to port A forces the pistons outwards, causing the springs to compress, the pinion turns clockwise while air is being exhausted from port B. Loss of air pressure on port A, the stored energy in the springs forces the pistons inwards. The pinion turns counterclockwise while air is being exhausted from port A.

Assemble, Parts and Material

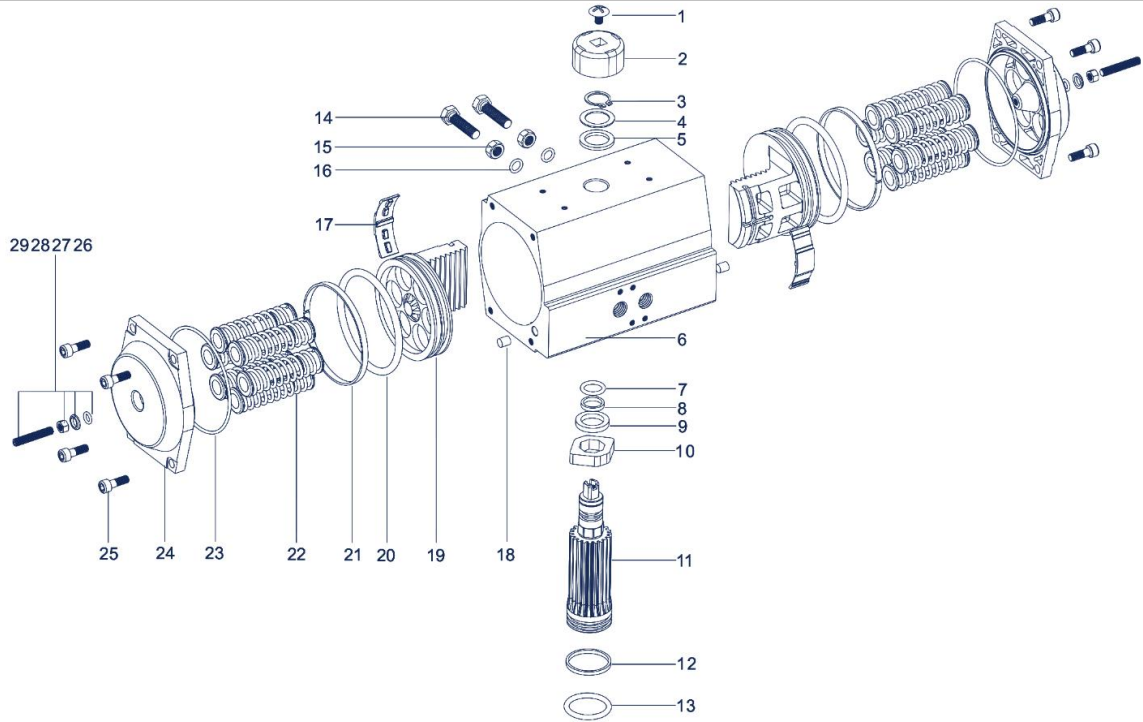

No.	Description	Qty	Standards Material	Protection	Optional Material
1	Indicator screw	1	Plastic(ABS)		
2	Indicator	1	Plastic(ABS)		
3	Spring clip	1	Stainless steel(304)		
4	Metal washer	1	Stainless steel(304)		
5	Outside washer	1	polyoxymethylene		
6	Body	1	Extruded aluminum alloy(6005-T5)	Hard anodized etc	
7	O-ring(pinion top)	1	NBR		Viton/silicone
8	Bearing(pinion top)	1	polyoxymethylene		
9	Inside washer	1	polyoxymethylene		
10	Travel stop	1	Alloy steel(45#)		
11	Pinion	1	Alloy steel(45#)	Nickel plated	Stainless steel
12	Bearing (pinion bottom)	1	NBR		Viton/silicone
13	O-ring(pinion bottom)	1	polyoxymethylene		
14	Adjust screw	2	Stainless steel(304)		
15	Nut (adjust screw)	2	Stainless steel(304)		
16	O-ring(adjust screw)	2	NBR		Viton/silicone
17	Plate(piston)	2	polyoxymethylene		
18	Hole sealant	2	NBR		Viton/silicone
19	Piston	2	Cast aluminum/casting(101A)	Anodized/zinc galvanized	Stainless steel
20	O-ring(piston)	2	NBR		Viton/silicone
21	Bearing (piston)	2	polyoxymethylene		
22	Spring	0~12	Spring steel	Dip coating	
23	O-ring(end cap)	2	NBR		Viton/silicone
24	End cap	2	Cast aluminum(ADC12)	Powder polyester painted etc	
25	Cap screw	8	Stainless steel(304)		
26	Adjust Screw O-ring	2	Viton/NBR		
27	Adjust Screw Washer	2	Stainless steel		
28	Adjust Screw Nut	2	Stainless steel		
29	Adjust Screw	2	Stainless steel		

Dimension Drawings

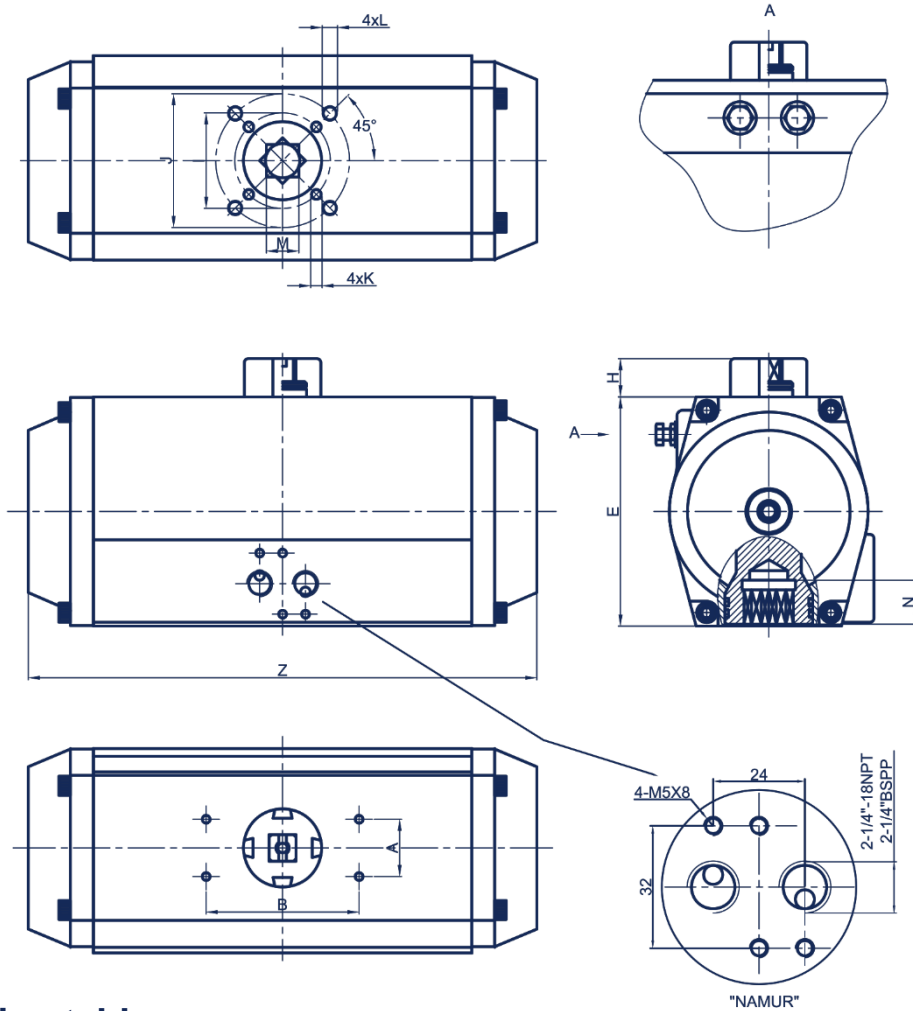

Dimension table

Unit : mm

Model	A	B	E	H	I	J	K	L	M	N	Z	Air Connection
SMART-40	30	80	60	20	Ø36	Ø50	M5x8	M6x10	11	14	120	1/4" BSP
SMART-52	30	80	74	20	Ø36	Ø50	M5x8	M6x10	11	14	146	1/4" BSP
SMART-63	30	80	88	20	Ø50	Ø70	M6x10	M8x13	14	18	168	1/4" BSP
SMART-75	30	80	100	20	Ø50	Ø70	M6x10	M8x13	14	18	184	1/4" BSP
SMART-83	30	80	109	20	Ø50	Ø70	M6x10	M8x13	17	21	204	1/4" BSP
SMART-92	30	80	120	20	Ø50	Ø70	M6x10	M8x13	17	21	260	1/4" BSP
SMART-105	30	80	133	20	Ø70	Ø102	M8x13	M10x16	22	26	268	1/4" BSP
SMART-125	30	130	155	20	Ø70	Ø102	M8x13	M10x16	22	26	289	1/4" BSP
SMART-140	30	130	171.5	20	Ø102	Ø125	M10x16	M12x20	27	31	390	1/4" BSP
SMART-160	30	130	197	20	Ø102	Ø125	M10x16	M12x20	27	31	458	1/4" BSP
SMART-190	30	130	230	30		Ø140			36	40	525	1/4" BSP
SMART-210	30	130	255	30		Ø140			36	40	532	1/4" BSP

Dimension Drawings

SMART-240

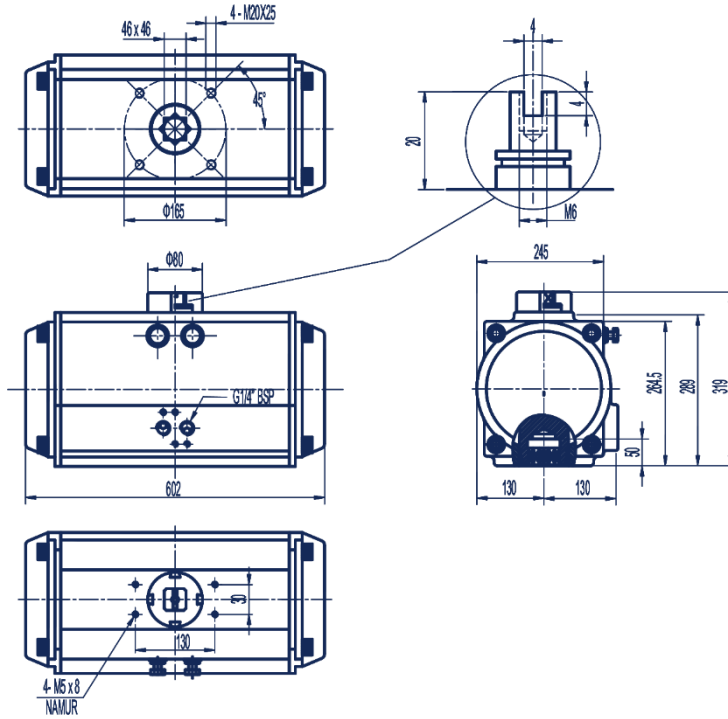

SMART-270

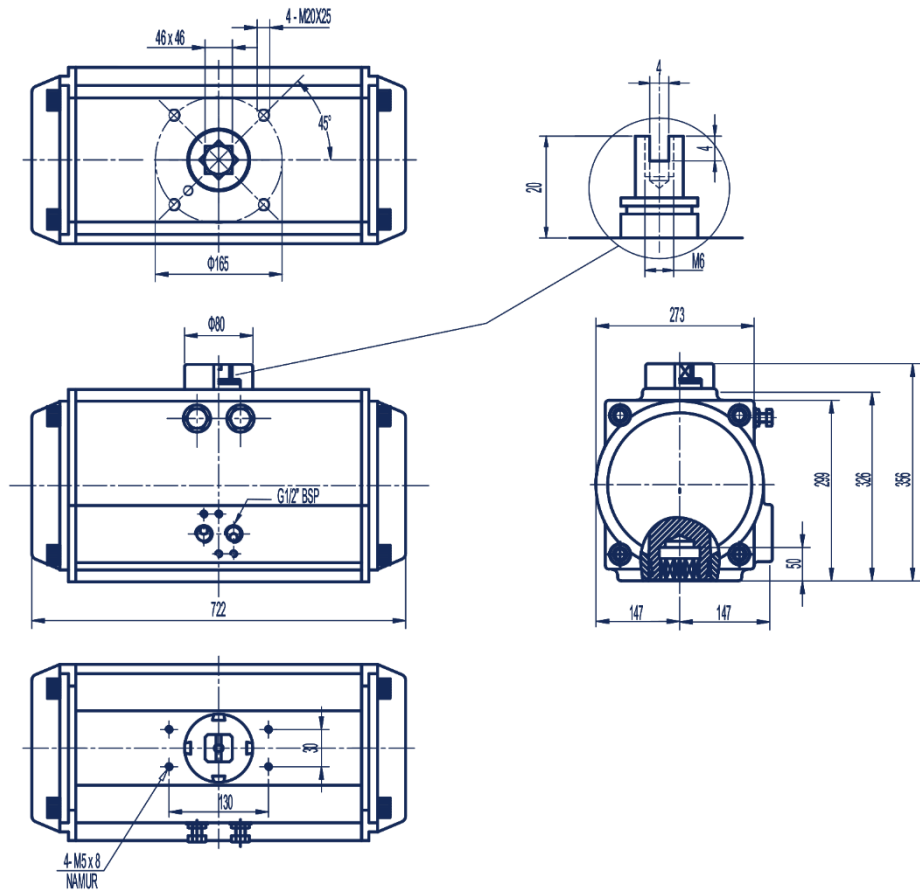

Out torque table of double acting

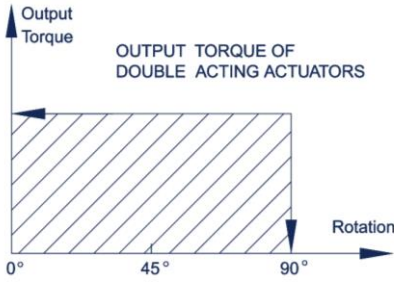

OUTPUT TORQUE OF DOUBLE ACTING ACTUATORS (Unit : Nm)									
Model	Air supply pressure (Unit : Bar)								
	2	2.5	3	4	5	6	7	8	10
SMART-40DA	4.8	6	7.2	9.5	11.9	14.3	16.7	19.1	21.0
SMART-52	8.1	10.1	12.1	16.1	20.2	24.2	28.2	32.3	40.3
SMART-63	14.4	18.0	21.7	28.9	36.1	43.3	50.5	57.7	72.2
SMART-75	20.1	25.2	30.2	40.3	50.3	60.4	70.5	80.5	100.7
SMART-83	31.2	39.0	46.8	62.4	78.0	93.6	109.2	124.8	156.0
SMART-92	45.4	56.8	68.2	90.9	113.6	136.3	159.1	181.8	227.2
SMART-105	65.8	82.2	98.7	131.6	164.4	197.3	230.2	263.1	328.9
SMART-125	102.5	128.2	153.8	205.1	256.4	307.6	358.9	410.2	512.7
SMART-140	175.4	219.3	263.1	350.8	438.5	526.2	613.9	701.6	877.0
SMART-160	267.3	334.1	400.9	534.6	668.2	801.8	935.5	1069.1	1336.4
SMART-190	430.7	538.4	646.1	861.5	1076.9	1292.2	1507.6	1723.0	2153.7
SMART-210	526.2	657.8	789.3	1052.4	1315.5	1578.6	1841.7	2104.8	2631.0
SMART-240	769.5	961.9	1154.3	1539.0	1923.8	2308.5	2693.3	3078.0	3885.8
SMART-270	1169.6	1462.1	1754.5	2339.3	2924.1	3508.9	4093.7	4678.6	5846.4

Out torque table of spring return

OUTPUT TORQUE OF SPRING RETURN ACTUATORS (Unit : Nm)																					
Output torque of air to springs																				Springs Output	
Air pressure	2Bar		2.5Bar		3Bar		4Bar		5Bar		6Bar		7Bar		8Bar		10Bar				
Model	Spring	0	90	0	90	0	90	0	90	0	90	0	90	0	90	0	90	0	90	90	0
	Q.ty	Start	End	Start	End	Start	End	Start	End	Start	End	Start	End	Start	End	Start	End	Start	End	Start	End
SMART 52SR	5	3,9	1,9	5,9	3,9	7,9	5,9	11,9	9,9	16,0	14,0									6,2	4,2
	6			5,0	2,7	7,0	4,7	11,0	8,7	15,1	12,8									7,4	5,1
	7					6,2	3,5	10,2	7,5	14,3	11,6	18,3	15,6							8,6	5,9
	8							9,3	6,2	13,4	10,3	17,4	14,3	21,4	18,3					9,9	6,8
	9							8,5	5,0	12,6	9,1	16,6	13,1	20,6	17,1	24,7	21,2			11,1	7,6
	10									11,7	7,8	15,7	11,8	19,7	15,8	23,8	19,9	31,8	27,9	12,4	8,5
	11									10,9	6,6	14,9	10,6	18,9	14,6	23,0	18,7	31,0	26,7	13,6	9,3
12											14,1	9,4	18,1	13,4	22,2	17,5	30,2	25,5	14,8	10,1	
SMART 63SR	5	7,6	4,0	11,2	7,6	14,9	11,3	22,1	18,5	29,3	25,7									10,4	6,8
	6			9,8	5,5	13,5	9,2	20,7	16,4	27,9	23,6									12,5	8,2
	7					12,1	7,1	19,3	14,3	26,5	21,5	33,7	28,7							14,6	9,6
	8							18,0	12,2	25,2	19,4	32,4	26,6	39,6	33,8					16,7	10,9
	9							16,6	10,1	23,8	17,3	31,0	24,5	38,2	31,7	45,4	38,9			18,8	12,3
	10									22,4	15,2	29,6	22,4	36,8	29,6	44,0	36,8	58,5	51,3	20,9	13,7
	11									21,1	13,2	28,3	20,4	35,5	27,6	42,7	34,8	57,2	49,3	22,9	15,0
12											26,9	18,3	34,1	25,5	41,3	32,7	55,8	47,2	25,0	16,4	
SMART 75SR	5	9,6	5,6	14,7	10,7	19,7	15,7	29,8	25,8	39,8	35,8									14,5	10,5
	6			12,5	7,8	17,5	12,8	27,6	22,9	37,6	32,9									17,4	12,7
	7					15,4	9,9	25,5	20,0	35,5	30,0	45,6	40,1							20,3	14,8
	8							23,4	17,1	33,4	27,1	43,5	37,2	53,6	47,3					23,2	16,9
	9							21,3	14,2	31,3	24,2	41,4	34,3	51,5	44,4	61,5	54,4			26,1	19,0
	10									29,2	21,3	39,3	31,4	49,4	41,5	59,4	51,5	79,6	71,7	29,0	21,1
	11									27,1	18,4	37,2	28,5	47,3	38,6	57,3	48,6	77,5	68,8	31,9	23,2
12											35,1	25,7	45,2	35,8	55,2	45,8	75,4	66,0	34,7	25,3	
SMART 83SR	5	15,4	8,2	23,2	16,0	31,0	23,8	46,66	39,4	62,2	55,0									23,0	15,8
	6			20,0	11,4	27,8	19,2	43,4	34,8	59,0	50,4									27,6	19,0
	7					24,7	14,6	40,3	30,2	55,9	45,8	71,5	61,44							32,2	22,1
	8							37,1	25,6	52,7	41,2	68,3	56,8	83,9	72,4					36,8	25,3
	9							33,9	21,0	49,5	36,6	65,1	52,2	80,7	67,8	96,3	83,4			41,4	28,5
	10									46,4	32,0	62,0	47,6	77,6	63,2	93,2	78,8	124,4	110,0	46,0	31,6
	11									43,2	27,4	58,8	43,0	74,4	58,6	90,0	74,2	121,2	105,4	50,6	34,8
12											55,6	38,4	71,2	54,0	86,8	69,6	118,0	100,8	55,2	38,0	

OUTPUT TORQUE OF SPRING RETURN ACTUATORS (Unit : Nm)

Output torque of air to springs

Model	Spring	2Bar		2.5Bar		3Bar		4Bar		5Bar		6Bar		7Bar		8Bar		10Bar		Springs Output	
		0	90	0	90	0	90	0	90	0	90	0	90	0	90	0	90	0	90	Start	End
		Q.ty	Start	End	Start	End	Start	End	Start	End	Start	End	Start	End	Start	End	Start	End	Start	End	Start
SMART 92SR	5	22,1	11,0	33,5	22,4	44,9	33,8	67,6	56,5	90,3	79,2									334,4	23,3
	6			28,8	15,6	40,2	27,0	62,9	49,7	85,6	72,4									41,2	28,0
	7					35,5	20,1	58,2	42,8	80,9	65,5	103,6	88,2							48,1	32,7
	8							53,6	35,9	76,3	58,6	99,0	81,3	121,8	104,1					55,0	37,3
	9							48,9	29,0	71,6	51,7	94,3	74,4	117,1	97,2	139,8	119,9			61,9	42,0
	10									66,9	44,9	89,6	67,6	112,4	90,4	135,1	113,1	180,5	158,5	68,7	46,7
	11									62,2	38,0	84,9	60,7	107,7	83,5	130,4	106,2	175,8	151,6	75,6	51,4
	12											80,3	53,8	103,1	76,6	125,8	99,3	171,2	144,7	82,5	56,0
SMART 105SR	5	34,2	16,6	50,6	33,0	67,1	49,5	100,0	82,4	132,8	115,2									49,2	31,6
	6			44,2	23,1	60,7	39,6	93,6	72,5	126,4	105,3									59,1	38,0
	7					54,4	29,8	87,3	62,7	120,1	95,5	153,0	128,4							68,9	44,3
	8							81,0	52,9	113,8	85,7	146,7	118,6	179,6	151,5					78,7	50,6
	9							74,7	43,0	107,5	75,8	140,6	108,7	173,3	141,6	206,2	174,5			88,6	56,9
	10									101,1	66,0	134,0	98,9	166,9	131,8	199,8	164,7	265,6	230,5	98,4	63,3
	11									94,8	56,1	127,7	89,0	160,6	121,9	193,5	154,8	259,3	220,6	108,3	59,6
	12											121,4	79,2	154,3	112,1	187,2	145,0	253,0	210,8	118,1	75,9
SMART 125SR	5	50,1	24,1	75,8	49,8	101,4	75,4	152,7	126,7	204,0	178,0									78,4	52,4
	6			65,4	34,1	91,0	59,7	142,3	111,0	193,6	162,3									94,1	62,8
	7					80,5	44,1	131,8	95,4	193,1	146,7	234,3	197,9							109,7	73,3
	8							121,3	79,7	172,6	131,0	223,8	182,2	275,1	233,5					125,4	83,8
	9							110,9	64,0	162,2	115,3	213,4	166,5	264,7	217,8	316,0	269,1			141,1	94,2
	10									151,7	99,6	202,9	150,8	254,2	202,1	305,5	253,4	408,0	355,9	156,8	104,7
	11									141,2	84,0	192,4	135,2	243,7	186,5	295,0	237,8	397,5	340,3	172,4	115,2
	12											181,9	119,5	233,2	170,8	284,5	222,1	387,0	324,6	188,1	125,7
SMART 140SR	5	89,6	46,4	133,5	90,3	177,3	134,1	265,0	221,8	352,7	309,5									129,0	85,8
	6			116,4	64,5	160,2	108,3	247,9	196,0	335,6	283,7									154,8	102,9
	7					143,0	82,6	230,7	170,3	318,4	258,0	406,1	345,7							180,5	120,1
	8							213,5	144,5	301,2	232,2	388,9	319,9	746,6	407,6					206,3	137,3
	9							196,4	118,7	284,1	206,4	371,8	294,1	459,5	381,8	547,2	469,5			232,1	154,4
	10									266,9	180,6	354,6	268,3	442,3	356,0	530,0	443,7	705,4	619,1	257,9	171,6
	11									249,8	154,8	337,5	242,5	425,2	330,2	512,9	417,9	688,3	593,3	283,7	188,7
	12											320,3	216,7	408,0	304,4	495,7	392,1	671,1	671,1	309,5	205,9
SMART 160SR	5	127,6	59,0	194,4	125,8	261,2	192,6	394,9	326,3	528,5	459,9									208,3	139,7
	6			166,1	84,1	232,9	150,9	366,6	284,6	500,2	418,2									250,0	168,0
	7					204,9	108,9	338,6	242,6	472,2	376,0	605,8	509,8							292,0	196,0
	8							311,6	201,6	445,2	335,2	578,8	468,8	712,5	602,5					333,0	223,0
	9							283,6	159,6	417,2	293,2	550,8	426,8	684,5	560,5	818,1	694,1			375,0	251,0
	10									389,2	251,2	522,8	384,8	656,5	518,5	790,1	652,1	1057,4	919,4	417,0	279,0
	11									361,2	210,2	494,8	343,8	628,5	477,5	762,1	611,1	1029,4	878,4	458,0	307,0
	12											466,8	301,8	600,5	435,5	734,1	569,1	1001,4	836,4	500,0	335,0
SMART 190SR	5	240,7	137,7	348,4	245,4	456,1	353,1	671,5	568,5	886,9	783,9									293,0	190,0
	6			311,4	186,4	419,1	294,1	634,5	509,5	849,9	724,9									352,0	227,0
	7					381,1	236,1	596,5	451,5	811,9	666,9	1027,2	882,2							410,0	265,0
	8							558,5	392,5	773,9	607,9	989,2	823,2	1204,6	1038,6					469,0	303,0
	9							520,5	334,5	735,9	549,9	951,2	765,2	1166,6	980,6	1382,0	1196,0			527,0	341,0
	10									697,9	490,9	913,2	706,2	1128,6	921,6	1344,0	1137,0	1774,7	1567,7	586,0	379,0
	11									659,9	431,9	875,2	647,2	1090,6	862,6	1306,0	1078,0	1736,7	1508,7	645,0	417,0
	12											837,2	589,2	1052,6	804,6	1268,0	1020,0	1698,7	1450,7	703,0	455,0
SMART 210SR	5	266,2	166,2	397,8	297,8	529,3	429,3	792,4	692,4	1055,5	955,5									360,0	260,0
	6			344,8	225,8	476,3	357,3	739,4	620,4	1002,5	883,5									432,0	313,0
	7					424,3	286,3	687,4	549,4	950,5	812,5	1213,6	1075,6							503,0	365,0
	8							635,4	477,4	898,5	740,5	1161,6	1003,6	1424,7	1266,7					575,0	417,0
	9							583,4	405,4	846,5	668,5	1109,6	931,6	1372,7	1194,7	1635,8	1457,8			647,0	469,0
	10									794,5	596,5	1057,6	859,6	1320,7	1122,7	1583,8	1385,8	2110,0	1912,0	719,0	521,0
	11									742,5	524,5	1005,6	787,6	1268,7	1050,7	1531,8	1313,8	2058,0	1840,0	791,0	573,0
	12											953,6	715,6	1216,7	978,7	1479,8	1241,8	2006,0	1768,0	863,0	625,0

OUTPUT TORQUE OF SPRING RETURN ACTUATORS (Unit : Nm)

Output torque of air to springs

Air pressure	2Bar		2.5Bar		3Bar		4Bar		5Bar		6Bar		7Bar		8Bar		10Bar		Springs Output		
	Spring	0	90	0	90	0	90	0	90	0	90	0	90	0	90	0	90	0	90	90	0
Model	Q.ty	Start	End	Start	End	Start	End	Start	End	Start	End	Start	End	Start	End	Start	End	Start	End	Start	End
SMART 240SR	5	359.5	215.5	552	409	744	600	1129	985											554	410
	6	277.5	104.5	470	297	662	489	1047	874	1432	1259									665	492
	7			388	187	580	379	964	764	1349	1149									775	575
	8					498	268	883	653	1267	1037	1652	1422	2037	1807					886	656
	9							800	542	1185	926	1569	1311	1954	1696					998	739
	10							718	431	1103	816	1488	1201	1872	1586	2257	1970			1108	821
	11									1021	705	1406	1090	1791	1474	2176	1859	2482.8	2166.8	1219	903
	12								939	594	1323	979	1708	1363	2093	1748	2400.8	2055.8	1330	958	
SMART 270SR	5	609.6	382.6	903	675	1195	968	1779	1552											787	560
	6	497.6	226.6	790	519	1083	811	1667	1396	2252	1981									943	672
	7			679	361	972	654	1556	1238	2141	1823									1101	783
	8					860	497	1444	1081	2029	1666	2614	2252	3199	2836					1258	895
	9							1332	923	1917	1509	2502	2094	3087	2678					1416	1007
	10							1220	767	1805	1352	2390	1937	2974	2521	3560	3107			1572	1119
	11									1693	1194	2278	1779	2862	2364	3448	2949	3915.4	3416.4	1730	1231
	12								1582	1037	2167	1623	2752	2207	3336	2792	2804.4	3259.4	1887	1342	

Air Consumption

Air volume opening & closing

Unit : L

Model	Air volume opening	Air volume closing	Model	Air volume opening	Air volume closing
SMART-40	0.05	0.06	SMART-125	1.6	1.4
SMART-52	0.12	0.16	SMART-140	2.5	2.2
SMART-63	0.21	0.23	SMART-160	3.7	3.2
SMART-75	0.3	0.34	SMART-190	5.9	5.4
SMART-83	0.43	0.47	SMART-210	7.5	7.5
SMART-92	0.64	0.73	SMART-240	11	9
SMART-105	0.95	0.88	SMART-270	17	14

Air consumption depends on Air Supply. Air volume and Action cycle times, the calculating as follows:

$$L/Min = \text{Air volume (Air volume Opening + Air volume closing)} \times \frac{[\text{Air Supply (Kpa)} + 101.3]}{101.3} \times \text{Action cycle times (/min)}$$

Weight

Unit : kg

Model	DA	SR	Model	DA	SR
SMART-40	0.8	-	SMART-125	8.9	10.11
SMART-52	1.38	1.45	SMART-140	13.25	15.55
SMART-63	2.03	2.05	SMART-160	20.14	24
SMART-75	2.7	2.9	SMART-190	31.3	35.25
SMART-83	3.13	3.6	SMART-210	46.8	54.8
SMART-92	4.6	5.22	SMART-240	67.28	80.2
SMART-105	6.77	6.85	SMART-270	96.9	118

Operating Conditions

1. Operating media

Dry or lubricated air, or the non-corrosive gas

The maximum particle diameter must be less than 30µm

2. Air supply pressure

The minimum supply pressure is 2.5 Bar

The maximum supply pressure is 10 Bar

3. Operating temperature

Standard(NBR O-ring): -20°C~+80°C

Low temperature(Silicon rubber O-ring): -35°C~+80°C

High temperature(Fluorubber O-ring): -15°C~+150°C

4. Travel adjustment

Have adjustment range of ±5° for the rotation at 0° and 90°

5. Application

Either indoor or outdoor

Manual of sizing and operation

Sizing

Double acting actuator

The suggested safety factor for double acting actuators under normal working conditions is 20%-30%.

Example:

The torque needed by valve = 100Nm

The torque considered safety factor (1+30%) = 130Nm

Air supply = 5Bar

According to the above table, we can choose the minimum model is SMART-105DA.

Spring return actuator

The suggested safety factor for spring return actuator under normal working conditions is 30-50%.

Example:

The torque needed by valve = 80Nm

The torque considered safety factor (1+30%) = 104Nm

Air supply = 5Bar

According to the table of spring return actuators output, we find output torque of SMART-140SR is:

Air stroke 0° = 318.5Nm

Air stroke 90° = 257.5Nm

Spring stroke 90° = 181Nm

Spring stroke 0° = 120Nm

All the output torque is large than we needed.

Attention:

During the restoration, the spring return actuators output torque will not be affected by the input

Economical sizing

During selecting the spring return actuators, we can choose the more reasonable and more economical actuators, if we know the different torque needed by the valve working at opening, operating and closing.

Example:

The max torque needed by the butterfly valve=104Nm

The torque after opened (operating) $104 \times 30\% = 32\text{Nm}$

Air supply=5Bar

We can select the SMART-125SR

Output torque is:

Air stroke $0^\circ = 141.4\text{Nm} > 104\text{Nm}$

Air stroke $90^\circ = 83.4\text{Nm} > 32\text{Nm}$

Spring stroke $90^\circ = 173\text{Nm} > 32\text{Nm}$

Spring stroke $0^\circ = 115\text{Nm} > 104\text{Nm}$

The above data show the actuators torque can satisfy the requirement of the butterfly valve.

Springs mounting

Springs mounting form for spring return actuators:

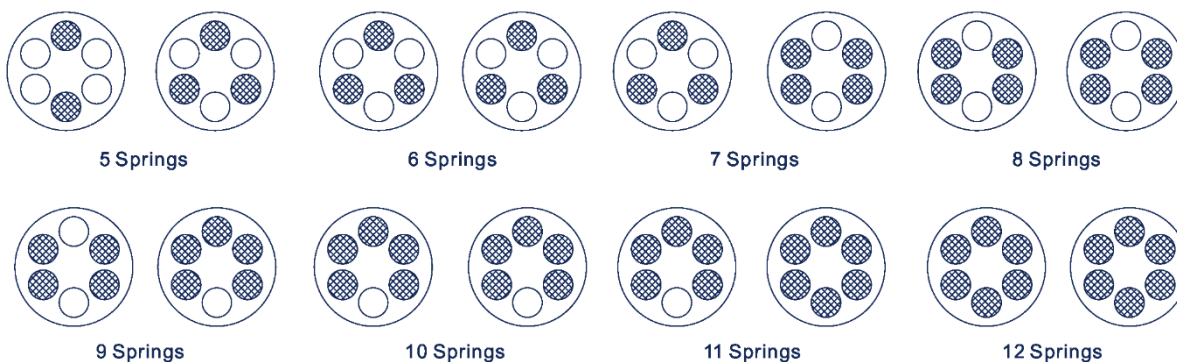

Assembly with valve

Remove any manual opening device from the valve, leaving the valve stem clear. Make sure that the shape of the stem fit the actuator output and that the rotation is not hindered in any way. Mount the actuator onto the valve, certaining it well on the stem. Make sure that the rotation direction is correct, in any case do not insert your hands inside the valve. We strongly suggest checking the cleanness of the air-supply pipes, especially when the plant is not provided with filters. A spacer between actuator and valve will be necessary with fluids at high temperature.

Maintenance

1. It is recommended that periodic checks be performed to make sure that all fasteners remain tight.
2. The actuator is supplied ready-lubricated no further lubrication is required. If lubrication is deemed necessary , use EP-1 grease.
3. Under certain working conditions (heavy duty, non-compatible operating media or abnormal operating conditions)internal seals should be checked periodically and replaced when necessary.
4. On spring return actuators, spring fatigue may set in requiring the replacement of springs. Spring should always be replaced in full sets.

NOTE

If an actuator is properly assembled and used, it will be maintenance free, as it has been lubricated enough to last a normal working life under normal working conditions. Should it get necessary to replace its seals, we suggest turning to Flucon where the product will be overhauled first, and then tested. On request, Flucon will be willing to provide its customers with kits and instructions.